



S272A

API Double Cartridge Seal

Materials

- Stationary - Car / SiC / SSiC / TC
- Rotary - SiC / SSiC / TC
- Elastomer - NBR / EPDM / Viton / Aflas / FFKM

Working Conditions

- Pressure ≤ 40 bar
- Speed ≤ 25 m/s
- Temperature up to 205°C

Features

- Stationary design
- Monolithic faces
- Cushioned faces
- Floating quench
- Springs outside of media
- Double pressure balanced
- Full pressure reversal
- Manual venting possible
- Ni-directional pumping device
- Optional hydro pads

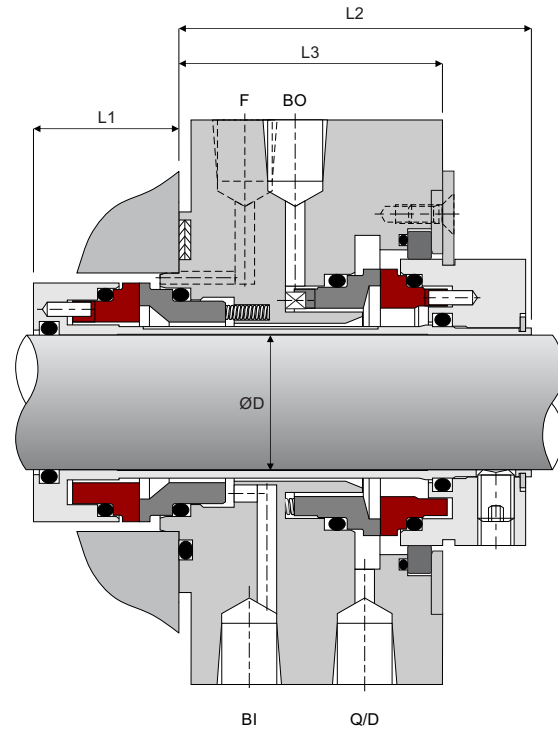

Inch ØD	Code	L1		L2		L3	
		mm	inch	mm	inch	mm	inch
1.000	0254	33	(1.299)	95	(3.740)	73.5	(2.894)
1.125	0286	33	(1.299)	95	(3.740)	73.5	(2.894)
1.250	0317	33	(1.299)	95	(3.740)	73.5	(2.894)
1.375	0349	33	(1.299)	95	(3.740)	73.5	(2.894)
1.500	0381	33	(1.299)	95	(3.740)	73.5	(2.894)
1.625	0412	33	(1.299)	95	(3.740)	73.5	(2.894)
1.750	0444	33	(1.299)	95	(3.740)	73.5	(2.894)
1.875	0476	33	(1.299)	95	(3.740)	73.5	(2.894)
2.000	0508	33	(1.299)	95	(3.740)	73.5	(2.894)
2.125	0539	33	(1.299)	95	(3.740)	73.5	(2.894)
2.250	0572	33	(1.299)	95	(3.740)	73.5	(2.894)
2.375	0603	33	(1.299)	95	(3.740)	73.5	(2.894)
2.500	0635	33	(1.299)	95	(3.740)	73.5	(2.894)
2.625	0666	33	(1.299)	95	(3.740)	73.5	(2.894)
2.750	0698	33	(1.299)	95	(3.740)	73.5	(2.894)
2.875	0730	33	(1.299)	95	(3.740)	73.5	(2.894)
3.000	0762	33	(1.299)	95	(3.740)	73.5	(2.894)
3.125	0794	33	(1.299)	95	(3.740)	73.5	(2.894)
3.250	0825	33	(1.299)	95	(3.740)	73.5	(2.894)
3.375	0857	33	(1.299)	95	(3.740)	73.5	(2.894)
3.500	0889	33	(1.299)	95	(3.740)	73.5	(2.894)
3.625	0921	33	(1.299)	95	(3.740)	73.5	(2.894)
3.750	0953	33	(1.299)	95	(3.740)	73.5	(2.894)
3.875	0984	33	(1.299)	95	(3.740)	73.5	(2.894)
4.000	1016	33	(1.299)	95	(3.740)	73.5	(2.894)

S272A Gland

- Details to be confirmed by customer:
- Gland OD
- Stuffing Box Bore
- Hole size (Stud size)
- Hole/Stud PCD
- Number of Bolts/Studs

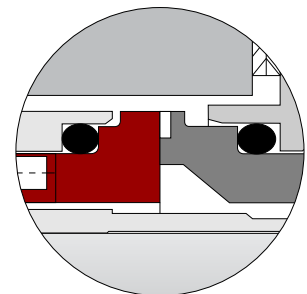

Optional Hydro Pads