

Materials

- Rotary - Sic / SSic / TC / SS
- Stationary SSW03 - Car / Sic / TC
- Stationary SSW04 - Car / Sic / TC
- Elastomer - NBR / EPDM / Viton / FFKM / Aflas

Working Conditions

- Pressure ≤ 20 bar
- Speed ≤ 5.5 m/s
- Temperature up to 205°C

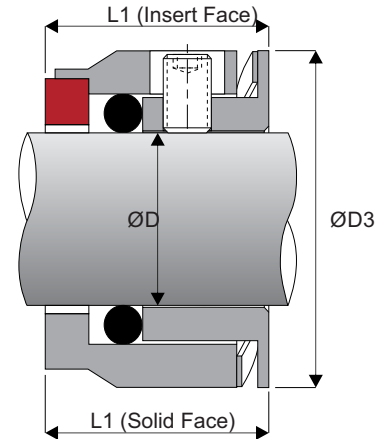

Shaft ØD	ØD3	L1		SSW03	
		Insert Face	Solid Face	L4	ØD7
20	32.4	20.5	20.0	10.5	30.0
30	44.0	21.9	21.4	11.1	41.3
35	50.8	22.5	22.0	12.0	47.0
38	53.7	22.5	22.0	12.0	50.3
45	62.4	23.4	22.9	12.6	58.3
55	76.0	29.8	29.3	13.2	69.6
60	82.8	30.4	29.9	13.6	75.2
65	87.6	31.0	30.5	14.0	80.9
75	99.2	31.6	31.1	14.4	92.2
80	106.0	32.3	31.8	14.7	97.8
100	127.2	34.1	33.6	15.9	120.4

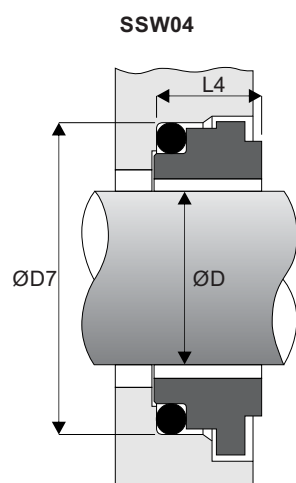
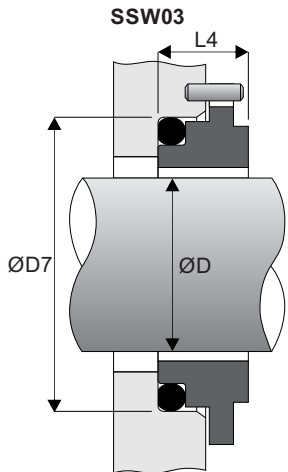

SSW04

Shaft ØD	ØD7	L4
30	40.0	9.3
35	44.5	9.2
50	62.0	10.4
70	85.0	14.1
80	95.0	16.2