

Materials

- Rotary - Car / Sic / SSic / TC
- Stationary - Sic / SSic / TC / SS
- Elastomer - NBR / EPDM / Viton

Working Conditions

- Pressure ≤ 25 bar
- Speed ≤ 20 m/s
- Temperature up to 205°C

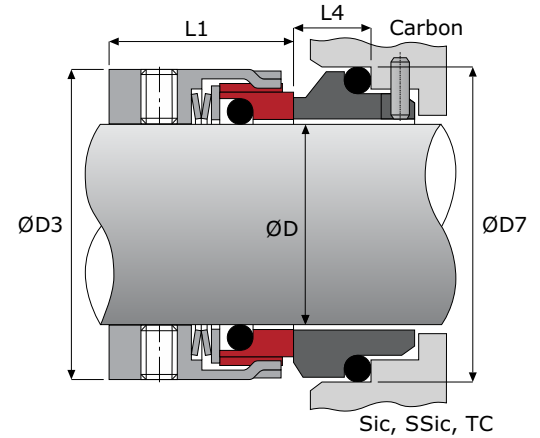

Shaft ØD	ØD3	L1	L1K	SS9	
				ØD7	L4
14	25	25.0	35.0	25	10.0
16	27	25.0	35.0	27	10.0
18	33	26.0	37.5	33	11.5
20	35	26.0	37.5	35	11.5
22	37	26.0	37.5	37	11.5
24	39	28.5	40.0	39	11.5
25	40	28.5	40.0	40	11.5
28	43	31.0	42.5	43	11.5
30	45	31.0	42.5	45	11.5
32	47	31.0	42.5	48	11.5
33	48	31.0	42.5	48	11.5
35	50	31.0	42.5	50	11.5
38	55	31.0	45.0	56	14.0
40	57	31.0	45.0	58	14.0
43	60	31.0	45.0	61	14.0
45	62	31.0	45.0	63	14.0
48	65	31.0	45.0	66	14.0
50	67	32.5	47.5	70	15.0
53	70	32.5	47.5	73	15.0
55	72	32.5	47.5	75	15.0
58	79	37.5	52.5	78	15.0
60	81	37.5	52.5	80	15.0
63	84	37.5	52.5	83	15.0
65	86	37.5	52.5	85	15.0
68	89	34.5	52.5	90	18.0
70	91	42.0	60.0	92	18.0
75	99	42.0	60.0	97	18.0
80	104	41.8	60.0	105	18.2