

### Items:

1. Stationary
2. Bearing Housing / End Cover
3. Static Stationary O-ring
4. Ingress Protector O-ring
5. Rotary O-ring
6. Rotary
7. Shaft
8. Drain to Bearings
9. Drain to Atmosphere

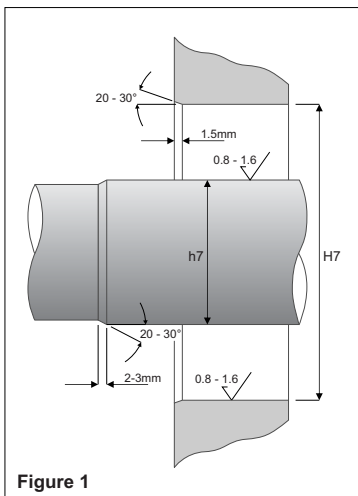
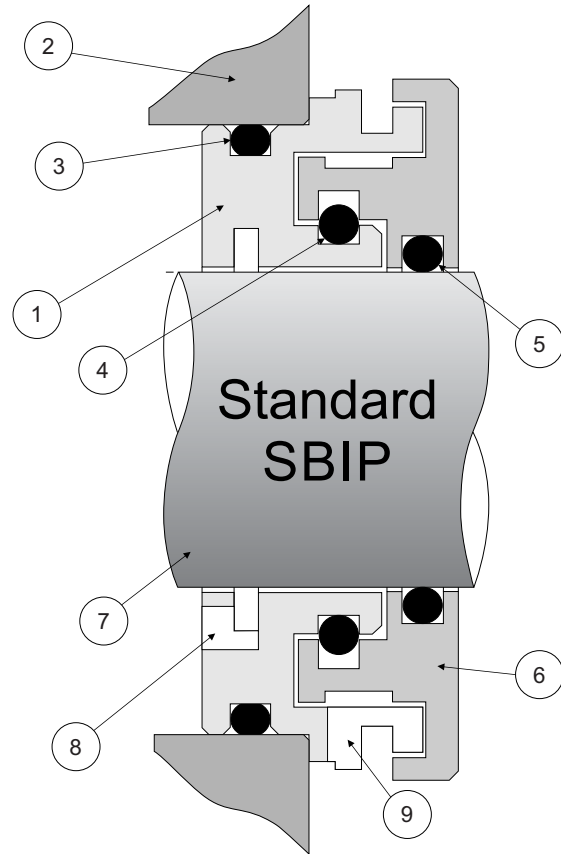

#### Step 1: Pre-installation checks

- Inspect the surface finish of the shaft and bearing housing to make sure that it is suitable for O-ring sealing.
- With a dial indicator, ensure that the shaft run out is less than 0.1mm T.I.R.
- Ensure that the dimensions and tolerances in Figure 1 are adhered to.
- Make sure that there are no sharp edges over which the seal O-rings (3,5) must pass, and the shaft and bearing housing have been cleaned before installation.

Figure 1

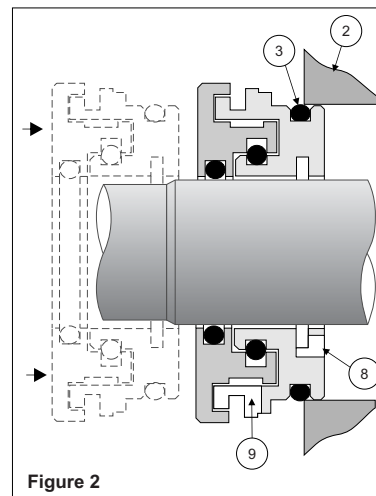

#### Step 2: Set rotary position

- Slide the SBIP/NMBS over the shaft until the static stationary O-ring (3) makes contact with the bearing housing end cover.
- Ensure that the drain holes (8,9) are located at the lowest point.
- Press the SBIP/NMBS into the bearing housing end cover carefully so as to not damage the shaft, bearing end cover or the SBIP/NMBS.
- Note that a small amount of soapy water may be used to assist with installation.

Figure 2

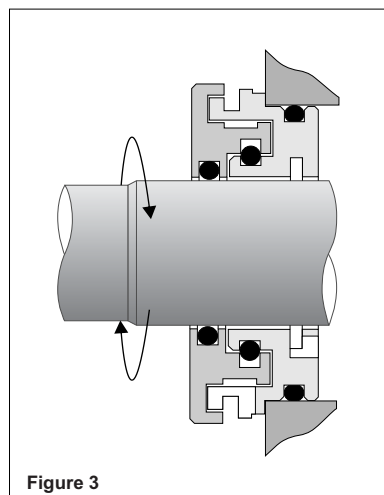

Figure 3

#### Step 3: Prepare stationary for installation

- Once the SBIP/NMBS is installed, turn the shaft by hand, listen and feel for any shaft binding.
- Ensure that the rotary part of the SBIP/NMBS turns with the shaft.
- If the shaft turns smoothly the equipment is ready to be commissioned.