

*Nexus PackTrac/SealTrac extends the life of gland packing and mechanical seals by expelling suspended solids away from sealing surfaces, which increases seal and packing life and reduces leakage.*

### **Nexus PackTrac and SealTrac**

Innovative designs of throat bushing to provide protection to the stuffing box for both gland packing and mechanical seals.

The unique spiral groove directs the rotating flow of gland water axially towards the impeller. This, together with a tapered groove results in a nozzle, effectively expelling solids trapped in the stuffing-box/seal chamber into the pump casing and away from sealing surfaces. The **SealTrac** air release groove ensures that air is not trapped in the seal chamber while the pump is idle.

*This results in longer life for packing, seals, and sleeves.*

A variety of sizes are available for various stuffing-box configurations, pump types and makes.

### **Features and Benefits**

- Effective expulsion of solids in process fluid
- Significantly reduce external flush fluid
- Limit product dilution
- Less leakage over time
- Greatly reduce sleeve wear
- Longer packing or seal life

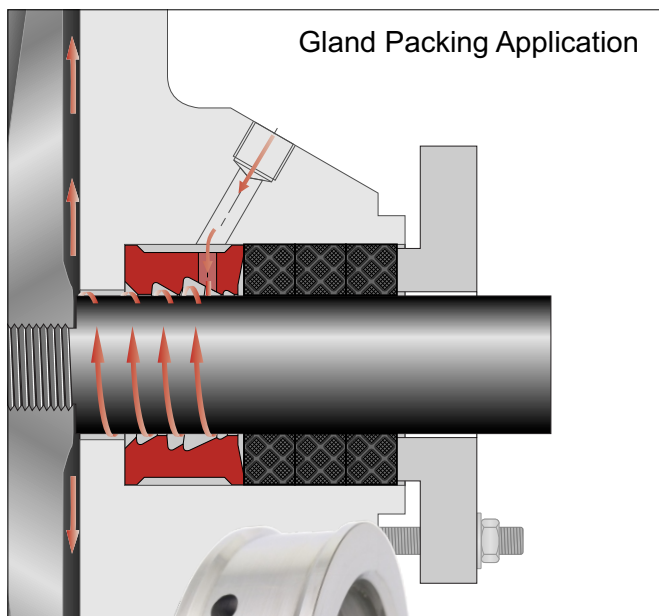

**Gland Packing  
PackTrac**

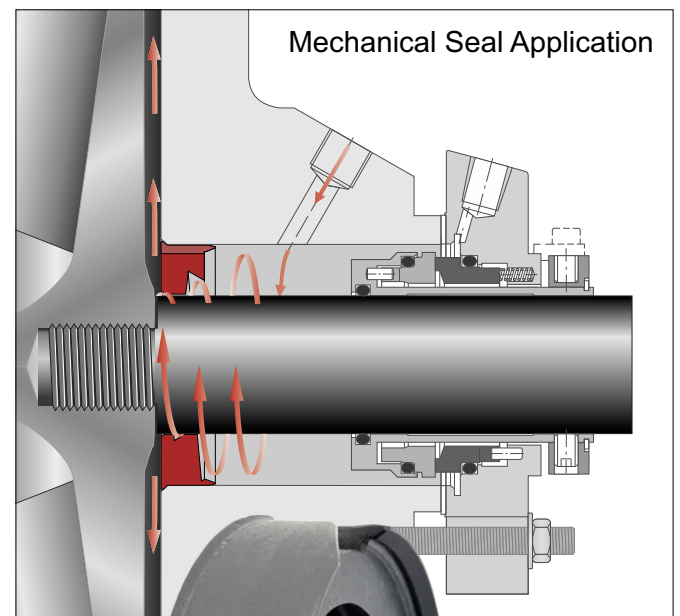

**Mechanical Seal  
SealTrac**

\*Nexus PackTrac to be used in conjunction with a Nexus SFM flow controller and check valve system.