

For water flows up to 13 litres per minute.

Clog resistant flow control valve and large flow channels.

APPLICATIONS

- Seal flush systems
- Single and double mechanical seals
- Gland packings
- Flow measurement

FEATURES

- Solid and reliable
- Extra large flow channels
- Clog resistant flow control valve
- Built-in tube cleaner
- Alarm ready
- Freeze resistant PSU tube available

MODEL	SFM-P	SFM-K	SFM-S
BODY MATERIAL	DELTRIN (POM)	KYNAR (PVDF)	316 S/S
Metering tube	Polysulphone (PSU), Borosilicate glass or PES	PES, Polysulphone (PSU) or Borosilicate glass	Borosilicate glass
Metallic parts	316 S/S or 304 S/S	316 S/S or 304 S/S	316 S/S
O-ring seals	Viton or EPDM	Viton or EPDM	Viton or EPDM
Maximum pressure	30 bar / 435 psi	30 bar / 435 psi	30 bar / 435 psi
Maximum temperature	100°C / 212°F (with PSU)	130°C / 266°F (with PSU)	130°C / 266°F
Connections	10mm or 12mm / 3/8" or 1/2" hose barbs 10mm / 3/8" OD straight tubes 10mm / 3/8" compression fittings (with nut and 2 ferrules) 6mm / 1/4" NPT male or female threads		
Weight (with pressure gauge, pressurizing valve and packaging)	1.5 kg (3.5 lb)	1.5 kg (3.5 lb)	3.2 kg (7.0 lb)
Build options	Body material, metering tube, metallic parts, O-ring seals, connections		
Optional accessories	Inductive adjustable alarm sensor and holder, pressure gauge (with optional red set pointer), floor mounting stand, pressurizing valve.		

SFM FLOW MONITOR		SFM	/	S	/	13	/	P		W		M	/	X		S		X
ARRANGEMENT	Single Double			S D														
FLOW LIMIT	1 LPM 3 LPM 8 LPM 13 LPM				01 03 08 13													
BODY MATERIAL	Delrin (POM) Kynar (PVDF) 316 S/S							P K S										
CONNECTION TYPE	3/8" ID hosebarb 1/4" NPT/M adapter 1/4" NPT/F adapter 1/2" OD straight tube 1/2" ID hosebarb 3/8" OD straight tube 3/8" compression fittings (c/w nut & ferrules) 10mm ID hosebarb 1/2" compression fittings (c/w nut & ferrules)								H M N O R S T W Y									
PRESSURE GAUGE	1 bar / 15 psi 2 bar / 30 psi 4 bar / 60 psi 7 bar / 100 psi 11 bar / 160 psi 14 bar / 200 psi 21 bar / 300 psi 28 bar / 400 psi 7 bar / 100 psi with red set pointer 11 bar / 160 psi with red set pointer 14 bar / 200 psi with red set pointer 21 bar / 300 psi with red set pointer 28 bar / 400 psi with red set pointer No pressure gauge									A B C D E F G H I J K L M X								
OPTIONS	Pressurizing valve (for double seal) No pressurizing valve													P X				
STAND	Floor mounting stand No stand															S X		
ALARMS	Alarm 10-55 VDC 150 mA (IG 5919) Alarm 20-250 VAC/DC 300 mA (IG 0374) No alarm																A X	

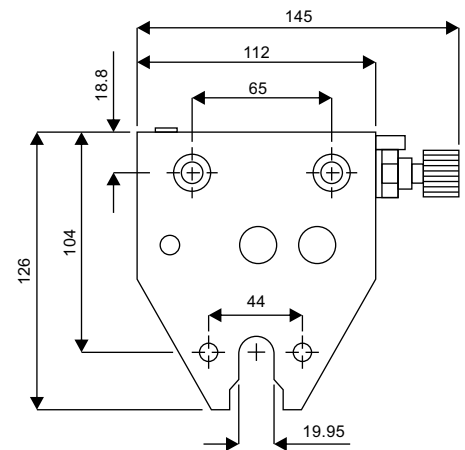
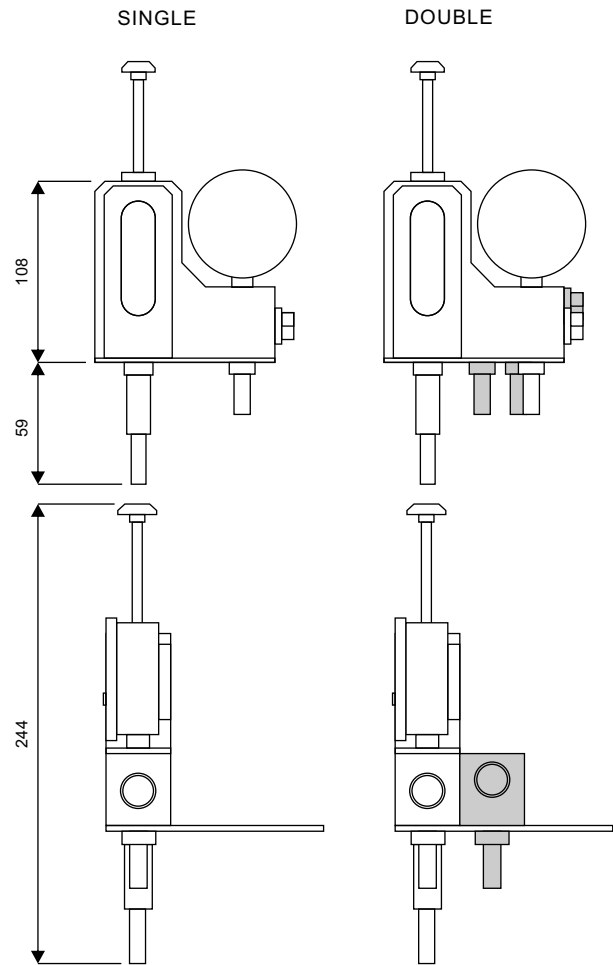

HOW TO SPECIFY MODEL NUMBER, an EXAMPLE: SFM/D08/PWM/PXX

Double SFM for 8LPM with POM end blocks, 10mm barb fittings, 28 bar pressure gauge, no stand and no alarm

1. Specify single or double
2. Specify flow rate
3. Select end block material
4. Specify connection type
5. Select pressure gauge
6. Pressurizing valve insert
7. Stand
8. Alarm

SFM/D
SFM/D08
SFM/D08/P
SFM/D08/PW
SFM/D08/PWM
SFM/D08/PWM/P
SFM/D08/PWM/PX
SFM/D08/PWM/PXX



BODY MATERIALS

FITTINGS

PRESSURE GAUGE

ALARM SENSOR



A full range of parts for all seal water meters sold by Nexus, past and present.

REPLACEMENT PARTS

- O-ring kits
- Floats
- Valves
- Pressure gauges

ACCESSORIES

- Mounting brackets
- Floor stands
- Check valves
- Proximity switches

CONTACT US FOR REPLACEMENT KITS, PARTS AND ACCESSORIES

O-ring kits	Viton or EPDM
Floats	Specify flow meter model number when ordering
Pressure gauges	With optional red set pointer
Floor mount stand for SFM meter	316 S/S construction
Check valves construction	316 S/S body, POM internals
Check valves fittings:	1/2" NPT x 1/2" hosebarb 1/2" NPT x 3/8" compression fitting 1/2" BSP x 3/8" hosebarb 3/8" NPT x 3/8" hosebarb 1/2" NPT x 3/8" hosebarb 3/8" NPT x 3/8" compression fitting 1/4" NPT x 1/4" NPT
Proximity switches:	
SF-PROX/150/DC	10-55 VDC, 150 mA NO/NC
SF-PROX/300/ACDC	20-250 VAC/DC, 300 mA NO

SFM FLOW MONITOR ACCESSORIES

STAND	TYPE
-------	------

SF-STAND	Floor mount stand for SFM meter
----------	---------------------------------

CHECK VALVES	TYPE
--------------	------

SF-2044	1/2" NPT x 1/2" hosebarb
SF-2004	1/2" NPT x 3/8" hosebarb
SF-2074	1/2" NPT x 3/8" compression fitting
SF-2005	1/2" BSP x 3/8" hosebarb
SF-2029	3/8" NPT x 3/8" hosebarb
SF-2075	3/8" NPT x 3/8" compression fitting
SF-2055	1/4" NPT x 1/4" NPT

PROXIMITY SWITCH TYPE

SF-PROX/150/DC	10-55 VDC, 150 mA NO/NC
SF-PROX/300/ACDC	20-250 VAC/DC, 300 mA NO

